

POS.	COD./KOD	NOTE/MERKE/NOTES/NOTA/NOTAS
1	0.10.81.40	
2	5.12.40.78	
3	0.55.12.02	
4	5.13.79.67	
5	5.12.06.66	
6	UNI 5931 M8x25	
7	5.17.10.67	
8	5.17.10.65	
9	5.18.25.60	
10	5.17.10.69	
11	UNI 5588 M6	
12	0.45.12.50	
13	0.60.62.05	
14	0.60.60.04	
15	UNI 6592 Ø16	
16	UNI 7473 M16	
17	5.40.19.35	
18	5.18.25.38	
19	UNI 5739 M6x20	
20	0.12.07.06	
21	7.11.35.24	
22	0.24.03.03	
23	5.87.08.52	
24	UNI 5739 M10x20	

POS.	COD./KOD	NOTE/MERKE/NOTES/NOTA/NOTAS
25	0.12.07.10	
26	UNI 5931 M6x20	
27	5.18.17.78	
28	5.15.26.08	
29	UNI 5588 M10	
30	5.18.17.62	
31	ISO 7380 M10x16	
32	5.18.17.77	
33	5.13.37.17	
34	UNI 5588 M8	
35	UNI 5923 M8x35	
36	0.12.07.08	
37	5.12.40.33	
38	5.14.20.86	
39	5.13.37.18	
40	0.14.00.82	
41	0.15.26.30	
42	5.05.01.38	
43	5.19.20.23	
44	0.55.14.05	
45	5.17.10.70	
46	5.15.26.09	
47	5.13.37.15	
48	UNI 6954 P8x9.5	

POS.	COD./KOD	NOTE/MERKE/NOTES/NOTA/NOTAS
49	5.13.08.69	
50	UNI 5739 M8x30	
51	5.14.20.91	
52		
53	5.10.03.33	
54	5.08.01.53	
55	UNI 5931 M5x12	
56	5.15.95.17	
57	0.40.04.05	
58	5.13.08.68	
59	5.15.26.07	
60	UNI 5931 M8x16	
61	5.13.79.66	
62	0.14.00.73	
63	5.15.15.07	
64	5.18.25.61	
65	5.13.37.16	
66	7.13.06.28	
67	4.13.04.52	
68	4.13.04.47	
69	5.15.15.58	
70	5.17.10.64	
71		
72	5.40.18.58	

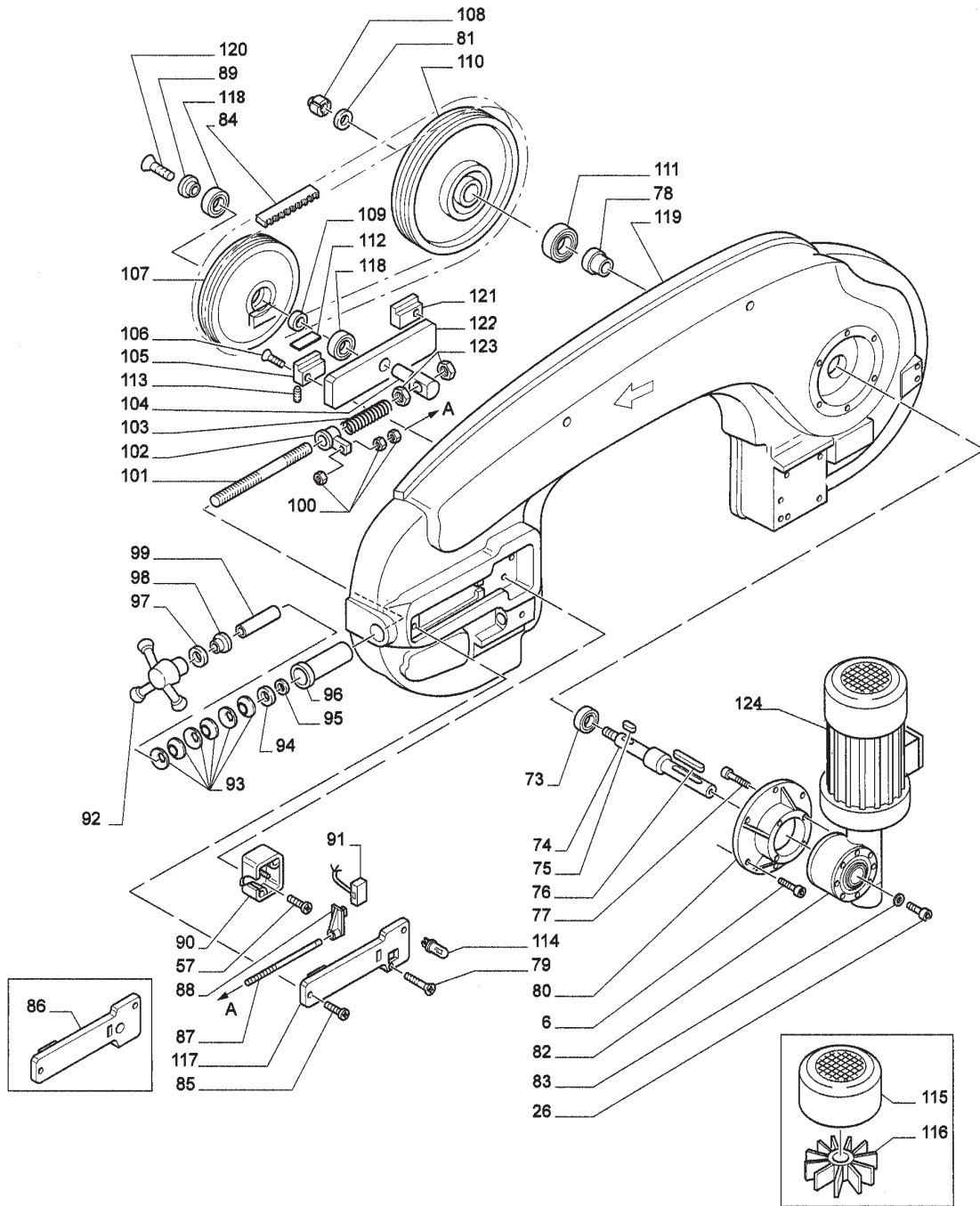

POS.	COD./KOD	NOTE/MERKE/NOTES/NOTA/NOTAS
73	0.59.64.05	
74	5.00.15.74	
75	0.15.01.52	
76	0.15.01.51	
77		
78	5.12.06.68	
79	0.42.07.69	
80	5.19.20.23	
81	0.12.01.21	
82	7.21.10.04	
83	5.12.40.79	
84	3.27.73.68	
85	0.40.04.05	
86	7.82.01.07	
87	5.14.20.59	
88	5.14.30.05	
89	5.12.40.60	
90	5.18.28.42	
91	0.80.11.01	
92	0.14.00.58	
93	0.08.02.60	

POS.	COD./KOD	NOTE/MERKE/NOTES/NOTA/NOTAS
94	UNI 6592 Ø16	
95	5.22.20.09	
96	5.06.60.16	
97	0.71.15.28	
98	5.12.40.30	
99	5.12.20.17	
100	UNI 5588 M4	
101	5.10.05.05	
102	5.14.20.58	
103	5.08.10.07	
104	5.00.15.75	
105	5.13.08.71	
106	UNI 5933 M6x25	
107	5.21.42.29	
108	0.10.61.20	
109	5.12.06.67	
110	5.21.40.30	
111	0.60.62.09	
112	5.15.20.72	
113	UNI 5923 M6x6	
114	0.89.40.08	

POS.	COD./KOD	NOTE/MERKE/NOTES/NOTA/NOTAS
115	5.18.28.85	
116	5.11.20.30	
117	5.18.25.31	
118	0.60.62.04	
119	5.04.28.11	
120	UNI 5933 M8x25	
121	5.13.08.70	
122	5.13.08.72	
123	UNI 5589 M12	
124	7.80.18.30	

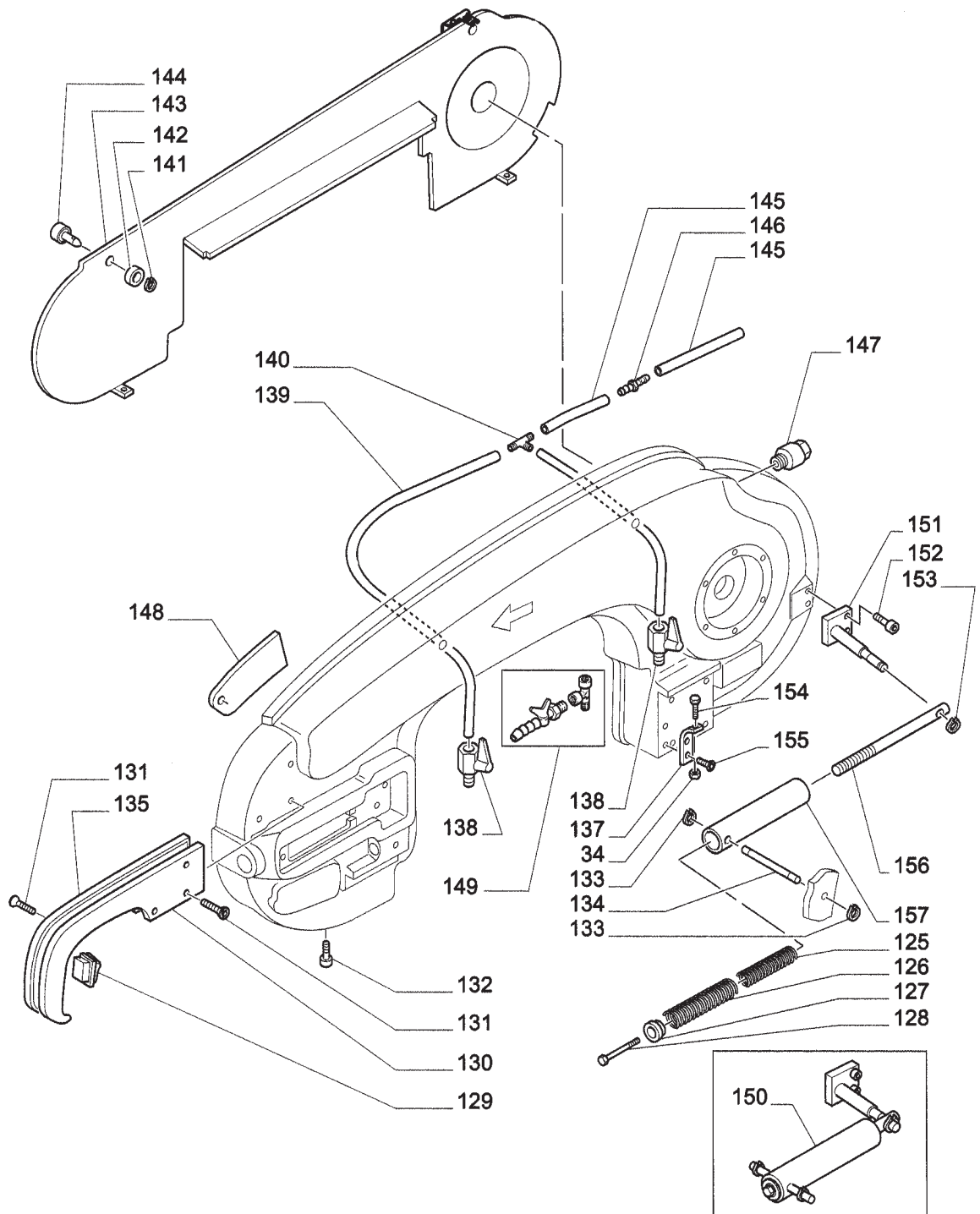

POS.	COD./KOD	NOTE/MERKE/NOTES/NOTA/NOTAS
125	5.08.01.56	
126	5.08.01.57	
127	5.12.40.80	
128	UNI 5739 M12x45	
129	0.80.23.24	
130	5.05.01.36	
131	UNI 5931 M5x15	
132	0.41.06.34	
133	UNI 7435 Ø12E	
134	5.15.15.09	
135	5.05.01.37	
136	0.42.07.66	
137	5.13.04.59	
138	0.24.03.05	
139	1.85.58.07	
140	0.24.14.48	
141	UNI 7435 Ø8E	
142	0.12.33.15	
143	5.18.17.70	
144	0.14.00.77	
145	1.85.58.08	

POS.	COD./KOD	NOTE/MERKE/NOTES/NOTA/NOTAS
146	0.24.14.47	
147	0.88.00.09	
148	5.18.17.79	
149	7.24.03.02	
150	7.13.06.27	
151	5.17.10.66	
152	UNI 5931 M8x20	
153	UNI 7435 Ø15E	
154	UNI 5739 M8x30	
155	UNI 5933 M6x25	
156	5.17.30.33	
157	5.04.00.11	

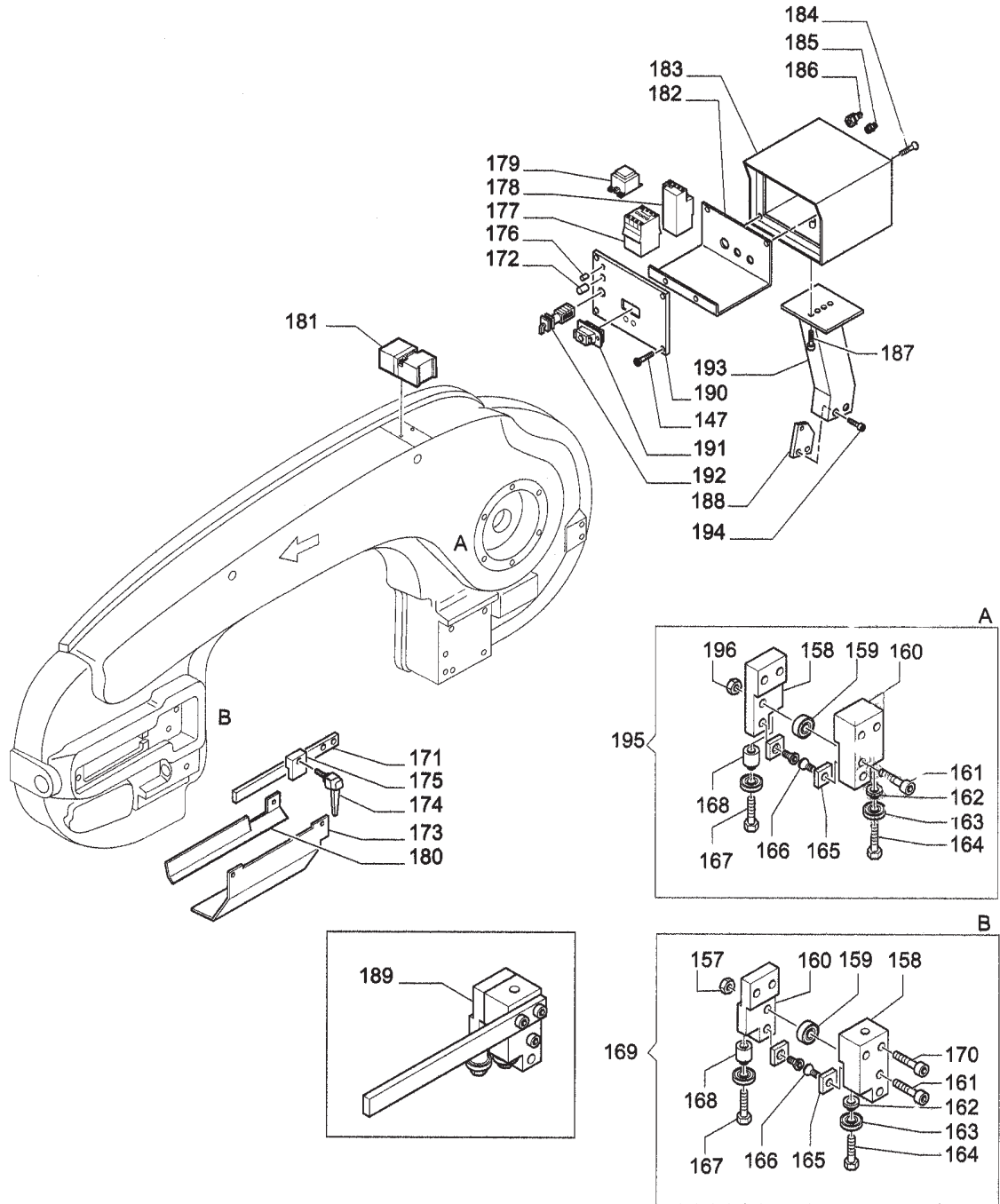

POS.	COD./KOD	NOTE/MERKE/NOTES/NOTA/NOTAS
158	5.13.08.65	
159	0.60.60.00	
160	5.13.08.67	
161	UNI 5931 M10x35	
162	5.12.06.69	
163	0.60.06.08	
164	UNI 5739 M6x20	
165	3.24.98.02	
166	0.38.04.15	
167	0.31.06.35	
168	5.12.06.70	
169	7.13.05.96	
170	UNI 5931 M6x40	
171	5.13.08.66	
172	0.89.40.09	
173	5.18.17.76	
174	0.14.70.18	
175	5.17.10.68	
176	0.89.21.02	
177	0.81.00.12	
178	0.81.00.03	

POS.	COD./KOD	NOTE/MERKE/NOTES/NOTA/NOTAS
179	0.84.02.05	
180	5.18.17.94	
181	0.80.12.06	
182	5.13.79.98	
183	5.07.00.02	
184	ISO 7380 M4x16	
185	0.88.00.07	
186	0.88.00.08	
187	UNI 5931 M6x20	
188	5.13.79.77	
189	7.13.25.06	
190	5.40.19.64	
191	0.80.26.25	
192	0.82.00.03	
193	5.13.79.70	
194	UNI 5931 M6x20	
195	7.13.05.95	
196	UNI 5589 M10	